

[CONTRIBUTION FROM THE DEPARTMENT OF CHEMISTRY, PURDUE UNIVERSITY, LAFAYETTE, INDIANA]

The Thermodynamic Properties of High Temperature Aqueous Solutions. VIII. Standard Partial Molal Heat Capacities of Gadolinium Chloride from 0 to 100^o¹

BY EUGENE C. JEKEL,² CECIL M. CRISS, AND J. W. COBBLE

RECEIVED MAY 15, 1964

The integral heat method was used to determine the partial molal heat capacities at infinite dilution of aqueous gadolinium chloride from 0 to 100^o. From the extrapolated values of the heats of solution at infinite dilution, values of $\overline{C}_{p_2}^{\circ}$ as a function of temperature have been calculated. For a representative 3-1 electrolyte, the observed heat capacities are negative and the heat capacity-temperature behavior is similar to that of other simple electrolytes. Since gadolinium chloride possesses such a high exothermic heat of solution, a more sensitive and accurate type of submarine calorimeter of short thermal lag was constructed. The description of this calorimeter, utilizing a thermistor sensing device, is presented in detail.

Introduction

Previous communications³⁻⁵ from these laboratories have described the usefulness and desirability of knowing thermodynamic properties of aqueous electrolyte solutions at temperatures above 25^o. One of the best methods of obtaining these quantities is to extend known thermodynamic functions at 25^o by use of partial molal heat capacities over the desired temperature range. The partial molal heat capacities of NaCl,³ BaCl₂,³ CsI,^{3,9} NaReO₄,⁴ and HReO₄⁴ from 0 to 100^o have been determined in these laboratories using the integral heat method. This method involves the calorimetric determination of the standard integral heats of solution from low concentration measurements extrapolated to infinite dilution over the temperature range in question.

In the present study, heats of solution for gadolinium chloride were determined from 1 to 95^o. As a representative 3-1 electrolyte, gadolinium chloride belongs to a class of substances whose heat capacities have not been heretofore determined in extremely dilute solutions, although some other thermodynamic functions are known. It is one of the largest simple trivalent ions and shows negligible hydrolysis over the temperature range involved. Since this electrolyte has a very negative partial molal heat capacity and also a very negative entropy, it is a key electrolyte in relating the partial molal ionic entropies at higher temperatures to the same quantity at 25^o.⁶

Experimental

Apparatus.—A new submarine calorimeter (CS-2) was designed and constructed so as to decrease the thermal lag present in the previously used instrument⁴ and therefore give more precise experimental measurements. The temperature-sensing element was a thermistor inserted in one leg of a Wheatstone bridge.

The calorimeter (Fig. 1) consists of a 450-ml. silvered cylindrical flask (H) which is supported from the lid of a brass vacuum chamber (G), 22 cm. high and 20 cm. in diameter. The lid of this container is fitted with three exit tubes. The 25 cm. × 4.2 cm. diameter exit tube (T) located in the center of the brass cylinder contains the stirring shaft (S). A Teflon adaptor ring (not shown) is attached to the stirring shaft encasement above the water level of the constant temperature bath. It narrows the encasement to 2.2 cm. and minimizes heat exchange between the calorimeter and the surroundings. The stirring shaft encase-

ment tube is connected to the brass cylinder by a brass ring (P). This permits the removal of the stirring assembly, thus providing access to the calorimetric vessel and stirring shaft.

The second exit tube (B) (36 cm. × 2.8 cm. diameter) is connected to the vacuum system by means of a threaded coupling (A) to allow evacuation of the chamber between the brass cylinder and the glass flask.

The third exit tube (Q) (30 cm. × 2.2 cm. diameter) is used as a conduit for the various electrical wires leading to the thermistor and heaters in the calorimetric vessel. The bottom of this exit tube contains a ceramic hermetic seal plug (N) through which all wires are connected.

There are four test tube like wells which extend down into the 450-ml. glass flask. One 6 cm. × 6 mm. diameter well contains the thermistor. A second 6 cm. × 9 mm. well contains a Chromel A wire-wound rough heater of approximately 6 ohms. The third 6 cm. × 9 mm. well contains the calibration heater composed of manganin wire of ~80 ohms. At present, the fourth well is not used.

The top of the flask has an outward flanged rim, to which an "O" ring (O) is fitted in such a way that when a vacuum is applied the assembly fits tightly against the metal mount on the brass cylinder. Four safety springs (E) connect the neck of the flask to the metal mount to protect the flask from accidental breakage. A flat cylindrical anvil (J) is located on the bottom of the flask and has an etched glass surface. The sample bulb (K) is broken on this anvil.

The entire stirring shaft and motor can be depressed in order to break the sample bulb. The motor is connected to a Bakelite shaft to minimize heat flow from the calorimeter. The Bakelite shaft is connected to a stainless steel shaft (S) which extends through two ball-bearing ring supports (C) in the stirring shaft encasement. A vapor trap (R) was built into the stirring shaft assembly. This can be filled with oil to ensure the calorimetry is carried out at constant pressure, yet will prevent significant air exchange. The stainless steel shaft is connected as it enters the flask (H) by a threaded metal ring (D) to a glass stirring rod (F) which contains four small paddles and a larger horseshoe paddle (L) surrounding the sample bulb. The sample bulb is finally connected to the stirring shaft by a rubber connector (M).

The stirring motor is mounted to a metal chassis, which contains fasteners to allow suspension of the calorimeter and vacuum container in the constant temperature bath.

The heating element of the calibration heater was made by winding about 80 in. of No. 36 manganin wire noninductively around a 6-mm. Pyrex tube. This was painted with Glyptal and baked for several hours. Four No. 30 copper lead wires were attached to carry the current and to measure the potential drop across the heater. The current leads were wrapped around the calorimeter to prevent heat loss from the calibration heater. The potential leads were connected to the current leads at a point 35% of the distance from the calorimeter to the submarine, thus eliminating the need of a correction for the heat generated in the leads. The space inside the well and tubing was filled with silicone grease to conduct heat from the heating elements to the calorimeter.

The constant temperature bath which contains the submarine calorimeter is controlled to ~0.001^o. It utilizes a thermistor in one leg of a resistance bridge. This bridge signal is fed into a Leeds and Northrup 9836-B D-C micromicroampere amplifier which in turn operates a proportional transistorized power control unit.^{8,9} The bath also contains a constant heater, and a cooling

(1) Supported in part by a grant from the National Science Foundation.

(2) From the Ph.D. Thesis of E. C. Jekel, Purdue University, 1964.

(3) C. M. Criss and J. W. Cobble, *J. Am. Chem. Soc.*, **83**, 3223 (1961).

(4) J. C. Ahluwalia and J. W. Cobble, *ibid.*, **86**, 5377 (1964).

(5) J. C. Ahluwalia and J. W. Cobble, *ibid.*, **86**, 5381 (1964).

(6) C. M. Criss and J. W. Cobble, *ibid.*, **86**, 5385 (1964).

(7) C. M. Criss and J. W. Cobble, *ibid.*, **86**, 5390 (1964).

(8) R. E. Mitchell and J. W. Cobble, *ibid.*, **86**, 5401 (1964).

(9) See also R. E. Mitchell, Ph.D. Thesis, Purdue University, 1964.

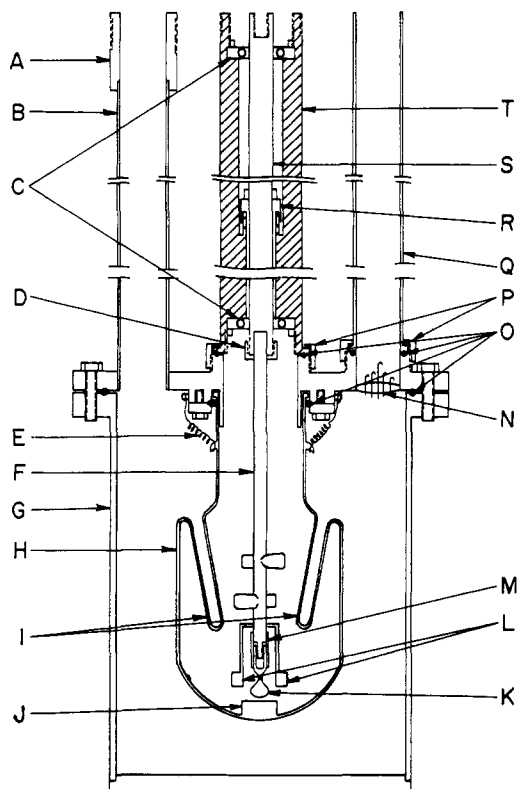

Fig. 1.—Submarine solution calorimeter (CS-2): A, coupling connector; B, vacuum tube; C, ball-bearing ring supports; D, threaded metal ring; E, safety springs; F, glass stirring rod; G, brass container; H, glass flask; I, thermistor and heater wells; J, cylindrical anvil; K, sample bulb; L, horseshoe paddle; M, rubber connector; N, hermetic seal plug; O, "O" rings; P, threaded metal ring; Q, exit tube for wires; R, vapor trap; S, stainless steel stirring shaft; T, stirring shaft encasement.

coil which circulates a methanol-water mixture from a refrigeration unit.

The thermistor used in this investigation, obtained from Fenwall Electronics, Inc., has a resistance of 10 kilohms at 25° with a negative temperature coefficient of $\sim 5\%$ per degree at 0° and $\sim 3\%$ per degree at 95°. It was placed in a glass tube and fixed in solder having a melting point of $\sim 115^\circ$. After cooling, the glass mold was removed, the solder was smeared with silicone grease to assure good thermal contact, and the mold was placed in the third well in the calorimetric vessel. Shielded cable was used to connect the thermistor to the bridge.

The modified Wheatstone bridge (Fig. 2) was specially designed in these laboratories,^{8,9} and gives equal bridge sensitivity before and after a calorimetric run. This design is useful for high impedance thermistors which change resistance rapidly over extended temperature ranges. The components of the bridge consist of the thermistor (T); a fixed 30-kilohm precision wire wound resistor (R_1); a 120-kilohm, precision 100-ohm step, Dekastat (R_2) [Electro Scientific Industries, Inc.] in series with a 100-ohm ten-turn helipot (R_3); and a fixed 25-kilohm, precision wire wound resistor (R_4) in series with a 12-kilohm, 1-ohm step, Dekastat (R_5). Two 1.34-v. mercury cells (E) supply the potential for the bridge. The linear d.c. amplifier was a Model 150 AR microvoltammeter [Keithley Instruments, Inc.]. The amplifier in turn drives a 2.5-mv. Servo-Riter recorder [Texas Instruments, Inc.]. The 120-kilohm, 100-ohm step, Dekastat (R_2) and 100-ohm ten-turn helipot (R_3) in the bridge panel are used to provide coarse balance of the bridge for the series of determinations at each temperature. These settings are left unchanged and only the 12-kilohm, 1-ohm step, Dekastat (R_5) is used to balance the bridge before and after each calorimetric run and electrical calibration. The sensitivity of the system is such that a 1-ohm change in the 12-kilohm Dekastat with the amplifier set on the 100- μv . range, corresponds to one scale width on the recorder paper or about 10^{-3}° . This represents a temperature sensitivity of $\sim 2 \times 10^{-6}^\circ$.

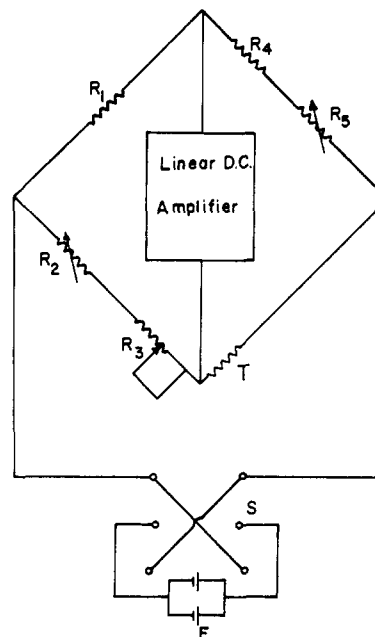

Fig. 2.—Thermistor bridge for CS-2: E, mercury cells; R_1 , 30-kilohm precision wire wound resistor; R_2 , 120-kilohm, precision, 100-ohm step, Dekastat; R_3 , 100-ohm, ten-turn helipot; R_4 , 25-kilohm fixed, precision wire wound resistor; R_5 , 12-kilohm 1-ohm step, Dekastat; S, switch; T, 10-kilohm thermistor.

The power source for the manganin wire calibration heater is a Sargent coulometric current source, Model IV. A separate electronic timer¹⁰ to switch off and on the current was constructed in these laboratories. The timer is powered by a 60-c.p.s. signal from a tuning-fork frequency standard [Riverbank Laboratories]. The timer can be present for the time interval desired and can shut off the heater current to an accuracy of at least 1 msec. Voltage across the heater and the current source voltage across a 10,000-ohm resistor are measured by a Model V 35 A digital voltmeter [Non-linear Systems, Inc.].

Materials.—All water used in the measurements and the preparation of GdCl_3 was prepared from distilled water repurified by ion exchange.

The gadolinium chloride was prepared by the action of hydrochloric acid on high purity gadolinium metal obtained from Michigan Chemical Corporation. A concentrated hydrochloric acid solution was made by passing pure hydrogen chloride gas through repurified water in a polyethylene beaker. A 32-g. piece of gadolinium metal was dissolved in the acid solution and cooled in ice-water to ensure a slower reaction. After several hours the residue was gray colored, consisting of crystals of gadolinium chloride hexahydrate and undissolved gadolinium metal. Enough water was added to dissolve the white crystals, the mixture was filtered, and hydrogen chloride was bubbled through the filtrate resulting in precipitation of white crystals of the gadolinium chloride hydrate.

These crystals were filtered and placed in a glass-tube furnace. Hydrogen chloride gas, dried by three sulfuric acid bubblers, was passed over the crystals at 80° for several hours until no condensed water was evident in the exit tube. The caked mass was removed from the tube, ground in a mortar, and returned to the hot tube. The exit of the hot tube was equipped with a sulfuric acid trap to prevent water vapor from reaching the gadolinium chloride. Dry hydrogen chloride gas was again passed over the crystals at 150, 250, and 375° for several hours at each temperature. The hot tube was rotated manually several times at each temperature to ensure complete mixing.

To ensure removal of adsorbed hydrogen chloride gas from the resulting crystals, the contents of the hot tube were transferred under drybox conditions to a long test tube. This tube was placed in the tube furnace, evacuated, and held at 375° for 24 hr.

The final gadolinium chloride preparation was stored in a dry-box desiccated with P_2O_5 .

(10) J. E. McDonald, Ph.D. Thesis, Purdue University, Aug., 1961.

TABLE I
 THE INTEGRAL HEATS OF SOLUTION AND ρ -VALUES OF GADOLINIUM CHLORIDE

No. of determinations	Molality ^a × 10 ⁴	$-\Delta H_s$, cal. mole ⁻¹	$6A_{HI}^{1/2\alpha}$, cal. mole ⁻¹	$-\rho$, cal. mole ⁻¹	No. of determinations	Molality ^a × 10 ⁴	$-\Delta H_s$, cal. mole ⁻¹	$6A_{HI}^{1/2\alpha}$, cal. mole ⁻¹	$-\rho$, cal. mole ⁻¹
		0.775°					55.035°		
1	2.498	39,821	71	39,892	1	2.172	47,022	149	47,171
1	4.473	39,807	94	39,901	1	2.859	47,161	174	47,335
1	10.940	39,905	134	40,039	1	3.333	47,070 ± 69	182	47,252 ± 69
1	28.743	39,772	225	39,997	1	7.474	47,092	269	47,361
1	46.940	39,793	283	40,076	3	11.917	46,861	336	47,197
		$\Delta H_s^\circ = -39,960 \pm 27$ cal. mole ⁻¹			1	21.227	46,741	441	47,182
		9.981°			1	24.467	46,825 ± 35	469	47,294 ± 35
1	4.127	41,260	104	41,364	1	26.914	46,592	491	47,083
1	11.809	41,253	172	41,425	1	32.547	46,478	535	47,013
1	18.218	41,336 ± 54	211	41,547 ± 54			$\Delta H_s^\circ = -47,210 \pm 49$ cal. mole ⁻¹		
1	28.434	41,194 ± 20	259	41,453 ± 20			64.928°		
		$\Delta H_s^\circ = -41,420 \pm 33$ cal. mole ⁻¹			1	2.909	48,128 ± 132	196	48,324 ± 132
		25.027°			1	3.494	48,228 ± 45	213	48,441 ± 45
1	2.074	43,414 ± 115	95	43,509 ± 115	1	6.731	48,037 ± 63	292	48,329 ± 63
1	2.520	43,368 ± 40	104	43,472 ± 40	1	10.694	48,183 ± 103	365	48,548 ± 103
1	3.492	43,318	121	43,439	1	17.778	48,012	464	48,476
1	5.226	43,422 ± 48	147	43,569 ± 48	1	26.123	47,944	553	48,497
1	6.409	43,231 ± 51	163	43,394 ± 51			$\Delta H_s^\circ = -48,480 \pm 42$ cal. mole ⁻¹		
1	6.958	43,197	169	43,366			74.903°		
1	8.155	43,356 ± 42	183	43,539 ± 42	1	3.059	49,367 ± 69	228	49,595 ± 69
1	16.240	43,282	255	43,537	1	8.532	49,480 ± 99	374	49,854 ± 99
1	20.884	43,210	284	43,494	1	11.400	49,488 ± 71	415	49,903 ± 71
1	24.020	43,169 ± 49	303	43,472 ± 49	1	17.820	49,291	527	49,818
1	31.790	43,280 ± 52	346	43,626 ± 52	1	22.187	49,310	584	49,894
		$\Delta H_s^\circ = -43,460 \pm 21$ cal. mole ⁻¹					$\Delta H_s^\circ = -49,860 \pm 62$ cal. mole ⁻¹		
		40.046°					84.964°		
1	3.230	45,070 ± 24	146	45,216 ± 24	2	5.444	50,592	340	50,932
1	3.813	45,101	158	45,259	1	10.494	50,622	469	51,091
1	4.272	45,214	166	45,380	1	11.542	50,622 ± 70	491	51,113 ± 70
2	4.708	45,023	174	45,197	2	14.568	50,561	562	51,123
2	8.798	45,034	237	45,271	1	21.355	50,526 ± 109	654	51,180 ± 109
1	11.030	45,101	263	45,364	1	28.044	50,434	740	51,174
1	11.668	45,001 ± 52	270	45,271 ± 52	1	33.314	50,154	804	50,958
1	13.838	45,018 ± 53	292	45,310 ± 53			$\Delta H_s^\circ = -51,220 \pm 48$ cal. mole ⁻¹		
1	16.756	44,979	319	45,298			94.865°		
1	26.041	44,785	392	45,177	2	5.676	51,970	395	52,365
		$\Delta H_s^\circ = -45,280 \pm 23$ cal. mole ⁻¹			2	8.160	52,352	473	52,825
					1	12.155	51,847 ± 71	574	52,421 ± 71
					1	13.015	52,152 ± 150	583	52,735 ± 150
					1	14.287	51,963 ± 114	626	52,589 ± 114
					1	20.459	51,797	728	52,525
					1	22.742	51,627 ± 114	764	52,391 ± 114
					1	31.771	51,302 ± 127	892	52,194 ± 127
							$\Delta H_s^\circ = -52,670 \pm 60$ cal. mole ⁻¹		

^a In those cases where more than one determination is used, the concentration listed is an average.

Procedure.—Thin-walled sample bulbs¹¹ were placed in a drybox several hours, inserted in a polyethylene stoppered glass vial, and removed from the drybox. Each vial containing a sample bulb was weighed to the nearest 0.01 mg. and returned to the drybox. After several hours, gadolinium chloride was placed in the sample bulbs, and each vial and contents was reweighed as before. Each sample bulb was then attached to a rubber connector on a glass stopcock in the drybox. This assembly was removed from the drybox and connected to a vacuum line, and the bulb was sealed off by melting the glass around the neck with a microtorch. Sample sizes ranged from 0.01 to 0.36 g. which resulted in calorimeter solutions of 0.0001 to 0.0053 *m*.

Techniques used in rough heating, balancing the bridge, and interpolation between unit resistances on the time-temperature drift lines were carried out as previously described.^{3,11} However, to improve experimental accuracy, usually more than one electrical calibration was carried out before and after sample dis-

solution. Each electrical equivalence (in calories/ohm) was plotted against the average of the bridge setting before and after the electrical heating. A straight line was obtained with a slight slope indicating higher electrical equivalence in calories/ohm at the lower bridge settings (higher temperatures). This is due to the nonlinearity of the thermistor. By averaging the resistance readings before and after sample dissolution, the energy equivalence of the calorimeter could therefore be conveniently and accurately obtained from this graph.

Several heats of bulb breaking were carried out at each temperature. A correction of -0.006 cal. for this exothermal effect was applied. Except for the smallest samples, this correction was less than 0.1%.

Calculations and Results

The standard heat of solution of gadolinium chloride at each temperature was obtained as before by extrapolation to infinite dilution using an extended Debye-

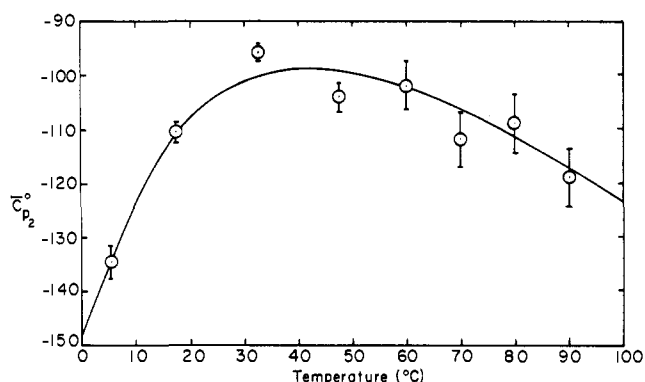

Fig. 3.—Standard partial molal heat capacities of GdCl₃(aq) from 0 to 100°.

Hückel treatment⁴

$$\rho = \Delta H_s^\circ - 2.303RT^2 \left(\frac{dB}{dT} \right)_{\nu+\nu-m} \quad (1)$$

where

$$\rho \equiv \Delta H_s - \frac{\nu}{2} |Z_+ Z_-| A_H I^{1/2} \alpha \quad (2)$$

and

$$\alpha \equiv \left| (1 + I^{1/2})^{-1} - \frac{\sigma(I^{1/2})}{3} \right| \quad (3)$$

For convenience the $I^{1/2}\alpha$ value was read from a previously prepared plot of I vs. $I^{1/2}\alpha$, where α was determined from eq. 3. The theoretical Debye-Hückel limiting slope A_H at each temperature was obtained from a table of values calculated elsewhere.^{8,9}

The standard partial molal heat capacity, $\overline{C}_{p_2}^\circ$, was determined from the following relationship.

$$\left(\frac{d\Delta H_s^\circ}{dt} \right)_p = \Delta C_p^\circ = \overline{C}_{p_2}^\circ - C_{p_2} \quad (4)$$

ΔH_s° was determined at small enough temperature intervals so that there was no significant difference between $d\Delta H_s^\circ/dt$ and $\Delta(\Delta H_s^\circ)/\Delta T$.

Table I lists the values of ΔH_s° for each measurement, the ρ -values, and the extrapolated values of the integral heats of solution at infinite dilution, ΔH_s° , for anhy-

TABLE II
HEAT CAPACITY DATA FOR CRYSTALLINE AND AQUEOUS
GADOLINIUM CHLORIDE

t_{av} , °C.	$-\Delta C_p^\circ$	$C_{p_2}^\circ$	$-\overline{C}_{p_2}^\circ$
5.38	159 ± 3	24	135 ± 3
17.50	135 ± 2	25	110 ± 2
32.54	121 ± 1	25	96 ± 1
47.54	129 ± 2	25	104 ± 2
59.98	128 ± 5	26	102 ± 5
69.92	138 ± 5	26	112 ± 5
79.93	135 ± 5	26	109 ± 5
89.96	145 ± 5	26	119 ± 5

^a For source of data on crystalline GdCl₃, see text; units in cal. deg.⁻¹ mole⁻¹.

drous gadolinium chloride. The most important criterion in linearly extrapolating ρ -values to infinite dilution on a ρ vs. m plot was that the resulting line be drawn among the experimental points to give the smallest average deviation for all of the data. The standard deviation of the data from the line finally drawn is indicated for each value of ΔH_s° . Further, the extrapolations were carried out in such a way that resulting values of $d\rho/dm$ were a smooth function of temperature. The heat ca-

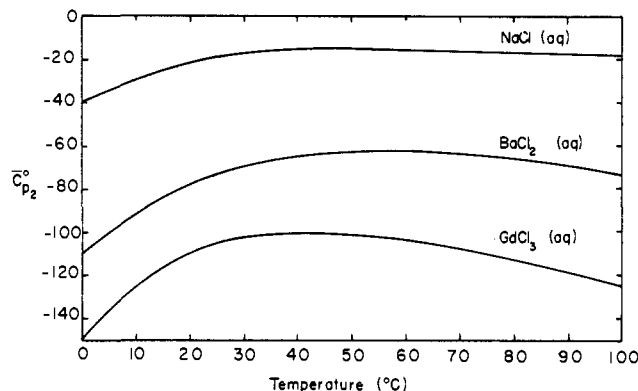

Fig. 4.—Smoothed values for the standard partial molal heat capacities of NaCl(aq), BaCl₂(aq), and GdCl₃(aq) from 0 to 100°.

pacities for the solution process, calculated from eq. 4, were also found to be a smooth function of temperature.

Table II summarizes the values of $\overline{C}_{p_2}^\circ$ evaluated from eq. 4. The heat capacity, C_{p_2} , at each temperature for anhydrous gadolinium chloride was estimated from the measurements of Hellwege, Küch, Niemann, and Pfeffer¹² on gadolinium chloride hexahydrate. A value of 58 cal. deg.⁻¹ mole⁻¹ for the six water molecules was subtracted from their extrapolated data to give the values of C_{p_2} reported in Table II. This value was obtained from other similar hydrates reported in the literature.¹³ Figure 3 shows standard partial molal heat capacities of GdCl₃(aq) from 0 to 100°. The error bars were estimated from the standard deviations of the ΔH_s° values.

Smoothed values of the standard partial molal heat capacities of GdCl₃(aq) are summarized in Table III. These values are preferred over the measured quantities

TABLE III
SMOOTHED VALUES OF THE STANDARD PARTIAL MOLAL HEAT
CAPACITIES OF GADOLINIUM CHLORIDE

t , °C.	$-\overline{C}_{p_2}^\circ$
0 ^a	140
10	124
20	108
25	104
30	101
40	99
50	100
60	102
70	107
80	112
90	117
100 ^a	123

^a Values at these temperatures were obtained by extrapolation

in Table II and are believed to possess an accuracy better than ± 5 cal. deg.⁻¹ mole⁻¹. Since $\overline{C}_{p_2}^\circ$ for GdCl₃(aq) is such a large value, the accuracy is probably better than 5%.

Figure 4 shows the smoothed $\overline{C}_{p_2}^\circ$ vs. temperature plot for GdCl₃(aq) along with NaCl(aq) and BaCl₂(aq) also determined in these laboratories.³ It shows the general trend of increasing negative partial molal heat capacities with increasing cationic charge. Also, the maxima in the curves seem characteristic for most electrolytes shown in this work and elsewhere.⁴

(12) K. H. Hellwege, F. Küch, K. Niemann, and W. Pfeffer, *Z. Physik*, **163**, 358 (1961).

(13) K. K. Kelley, U. S. Bureau of Mines Bulletin 584, U. S. Government Printing Office, Washington, D. C., 1960.